

- 1 0.00076[.000030] GOLD AT POINT OF MEASUREMENT, 0.00051[.000020] MIN AT THE END POINTS OF AREA G, (LOCALIZED GOLD PLATE AREA), 0.0038[.000150] TIN-LEAD ON LOCALIZED TIN PLATED AREA, ALL OVER 0.0013[.000050] NICKEL
- 2 USE 1.32±0.02 [.0520±.0010] DRILLED HOLE (#55 DRILL). FINISH TO BE TIN PLATE OVER 0.02 [.001] MIN COPPER.
- 3 DIMENSION APPLIES AT BASE OF SHROUD.
- 4 THE NOTED DIMENSIONS APPLY AT THE MATING FACE OF THE HOUSING.
- 5 0.0038 [.000150] TIN-LEAD ON HOLD DOWN, ALL OVER 0.0013 [.000050] NICKEL.
- 6. IF PLANNING TO USE MORE THAN ONE MATING PAIR OF CONNECTORS TO INTERCONNECT 2 BOARDS, PLEASE REFER TO SPACING PARAGRAPH IN APPLICATION SPEC, #114-7010
- 7 POINT OF MEASUREMENT
- 8 DIMENSIONS NOTED APPLY FROM THE BASIC DIMENSION LINE (NOT THE CIRCUIT CAVITY CENTER LINE) TO THE SURFACE INDICATED.
- 9 0.00076(0.000030) GOLD AT POINT OF MEASUREMENT, 0.00051(.000020) MIN AT THE END POINTS OF AREA G, (LOCALIZED GOLD PLATE AREA), 0.0038(.000150) TIN ON LOCALIZED TIN PLATED AREA, ALL OVER 0.0013(.000050) NICKEL.
- 10 0.0038(.000150) TIN ON HOLDDOWN, ALL OVER 0.0013 (.000050) NICKEL.
- 11 ROHS 2002/95/EC COMPLIANT

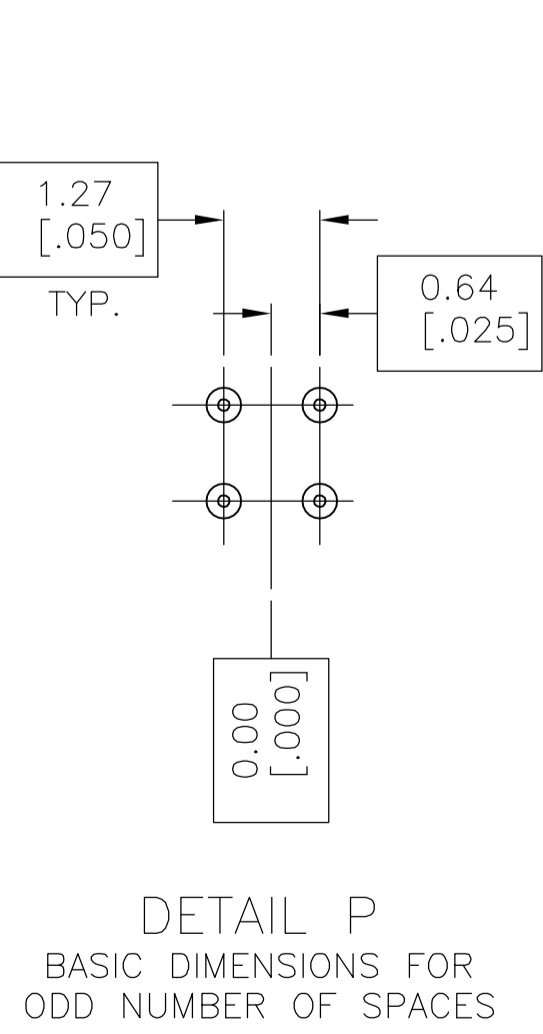
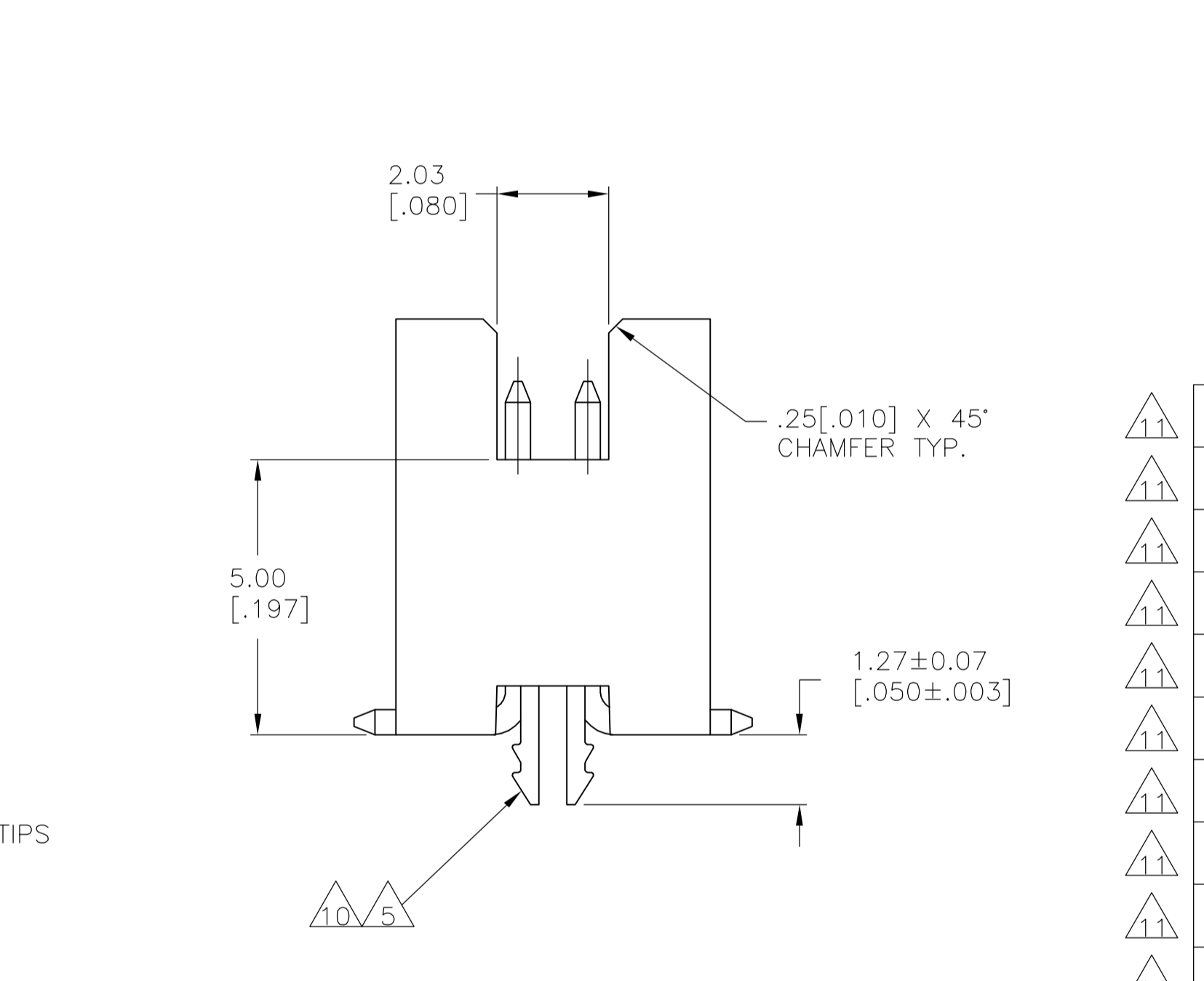
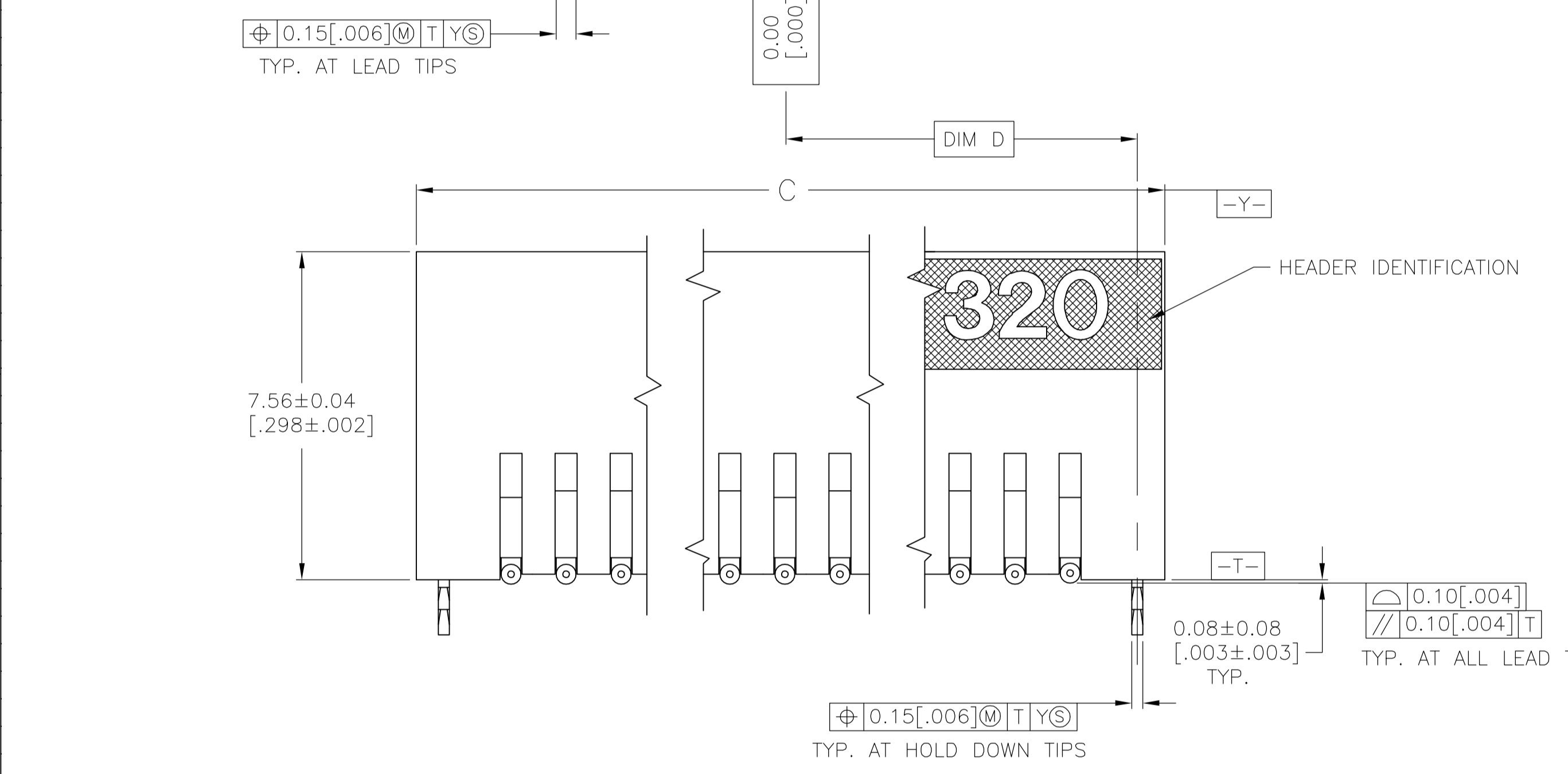

FINISH	E	D	C	B	A	NUMBER OF POSITIONS	PART NUMBER	
11	9/10	65.33 [2.572]	32.66 [1.286]	66.59 [2.622]	64.05 [2.522]	49	100	6-104656-0
11	9/10	58.98 [2.322]	29.48 [1.161]	60.24 [2.372]	57.70 [2.272]	44	90	5-104656-9
11	9/10	52.63 [2.072]	26.31 [1.036]	53.89 [2.122]	51.35 [2.022]	39	80	5-104656-8
11	9/10	46.28 [1.822]	23.13 [0.911]	47.54 [1.872]	45.00 [1.772]	34	70	5-104656-7
11	9/10	39.93 [1.572]	19.96 [0.786]	41.19 [1.622]	38.65 [1.522]	29	60	5-104656-6
11	9/10	33.58 [1.322]	16.78 [0.661]	34.84 [1.372]	32.30 [1.272]	24	50	5-104656-5
11	9/10	27.23 [1.072]	13.61 [0.536]	28.49 [1.122]	25.95 [1.022]	19	40	5-104656-4
11	9/10	20.88 [0.822]	10.43 [0.411]	22.14 [0.872]	19.60 [0.772]	14	30	5-104656-3
11	9/10	14.53 [0.572]	7.26 [0.286]	15.79 [0.622]	13.25 [0.522]	9	20	5-104656-2
11	9/10	8.18 [0.322]	4.08 [0.161]	9.44 [0.372]	6.90 [0.272]	4	10	5-104656-1
1/5		65.33 [2.572]	32.66 [1.286]	66.59 [2.622]	64.05 [2.522]	49	100	1-104656-0
1/5		58.98 [2.322]	29.48 [1.161]	60.24 [2.372]	57.70 [2.272]	44	90	104656-9
1/5		52.63 [2.072]	26.31 [1.036]	53.89 [2.122]	51.35 [2.022]	39	80	104656-8
1/5		46.28 [1.822]	23.13 [0.911]	47.54 [1.872]	45.00 [1.772]	34	70	104656-7
1/5		39.93 [1.572]	19.96 [0.786]	41.19 [1.622]	38.65 [1.522]	29	60	104656-6
1/5		33.58 [1.322]	16.78 [0.661]	34.84 [1.372]	32.30 [1.272]	24	50	104656-5
1/5		27.23 [1.072]	13.61 [0.536]	28.49 [1.122]	25.95 [1.022]	19	40	104656-4
1/5		20.88 [0.822]	10.43 [0.411]	22.14 [0.872]	19.60 [0.772]	14	30	104656-3
1/5		14.53 [0.572]	7.26 [0.286]	15.79 [0.622]	13.25 [0.522]	9	20	104656-2
1/5		8.18 [0.322]	4.08 [0.161]	9.44 [0.372]	6.90 [0.272]	4	10	104656-1

RECOMMENDED BOARD LAYOUT
SCALE 5:1

THIS DRAWING IS A CONTROLLED DOCUMENT.

DIMENSIONS: mm [INCHES]

TOLERANCES UNLESS OTHERWISE SPECIFIED:

0 PLC	±	-
1 PLC	±	-
2 PLC	±	0.13 [.005]
3 PLC	±	-
4 PLC	±	-
ANGLES	±	0° 30'

MATERIAL: HOUSING: LCP, COLOR-BLACK
POST: PHOS BRONZE
HOLD DOWN: COPPER ALLOY

FINISH: SEE TABLE

DW: KATE HELM 08/07/91
CHK: D. GORENC 8/12/91
APP'D: D. GORENC 8/12/91

NAME: Tyco Electronics Corporation
Harrisburg, Pa 17105-3608

PRODUCT SPEC: 108-1332
APPLICATION SPEC: 114-7010

SIZE: A1
WEIGHT: -

HEADER ASSEMBLY, SURFACE MOUNT, AMPMODU 50/50 GRID (8.12[.320] MATED HEIGHT)

CUSTOMER DRAWING

SCALE: 10:1 SHEET: 1 OF 1 REV: J1